

## Specification and scope of supply of P150.35

Description	Specification/scope of supply
Max component length	1500mm
Max component width	1000mm
Max component thickness	350mm
Max component weight	250kg – UDL (Uniformly Distributed Load)
Measuring accuracy, length & width**	+/- 35/70µm*
Measuring accuracy, height** (optional)	+/- 200 µm
Measuring speed**	<0.25sec
Camera	Industrialized ultra high resolution professionally mounted in sealed enclosure
Computer processor	Intel Quad Core
Processor speed	<3GHz
Hard disk	<125Gb
Screen	20 inch flatscreen or better
Peripheral equipment	Keyboard and optical mouse
Operating software	Windows 10- 64 Bit
Proprietary InspecVision software	Inspection, SPC, Reporting, Reverse engineering
Data cable	USB2 or USB3
KVM	Keyboard, Video Display & Mouse stand (PC integrated into light table assembly)
Light table construction	Frame with removable sheet metal cladding
Light table measuring surface	Laminate glass, toughened with integral diffusion layer
Light source	High efficiency LEDs
Mast construction	Heavy folded sheet metal construction
Power supply	230 Volt, single phase, 50Hz, (Grounded Mains Plug to IEC C13 lead supplied) or 110 Volt, single phase, 60Hz, (Grounded Mains Plug to IEC C19 lead supplied) on request
Power consumption	10 Amp maximum at 230 Volt, 15 Amp max at 110 Volt
Protective devices	Circuit breakers, mounted at rear of light table
Control panel	Control switches for power, camera and lights. Main power indicator
EC directives	Compliant with Machinery, Low voltage and EMC Directives
Paint colour (powder paint)	RAL5013 (cobalt blue)
Ambient operating conditions	10-30 degree C
Approx Footprint/installed width/ depth/ height/ weight of installed Light table and Mast	1870mm (W) x 1482mm (D) x 3988mm (H) <825kgs
Approx Footprint/installed width/ depth/ height/weight of KVM)	710mm (W) x 472mm (D) x 1739 (H) <95kgs
Standard packing	Export crates suitable for sea shipping (2 nos)
Warranty	One year limited warranty on hardware and software
Optional extended warranty	Two or three year extended warranty (requires software upgrade option)
Software support option	Annual support contract provides free software upgrades

\*The first accuracy value specifies the accuracy achieved over most of the table, the second accuracy value specifies the accuracy achieved at table edges

\*\*Accuracy results are verified on standard production machines using tests based on ISO 10360

Actual measuring accuracies achieved will depend on operating environment, user input, quality and condition of materials

Errors and omissions excepted

Due to our policy of continuous improvement specifications are subject to change without notice, please contact factory or your InspecVision dealer

# P150.35 Schematic

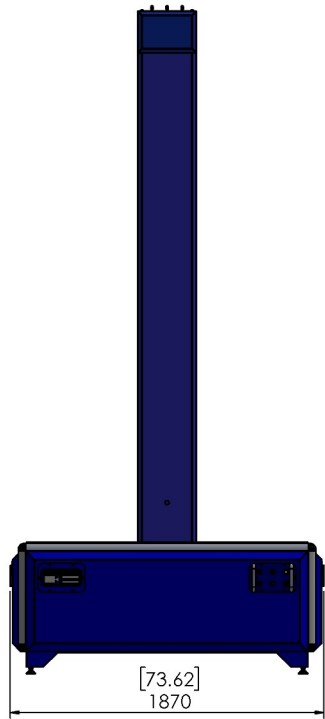
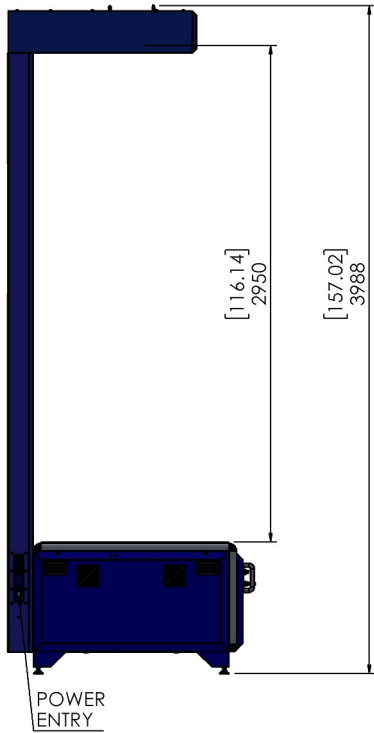
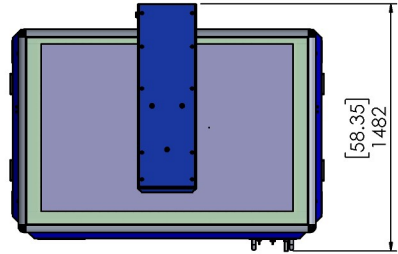
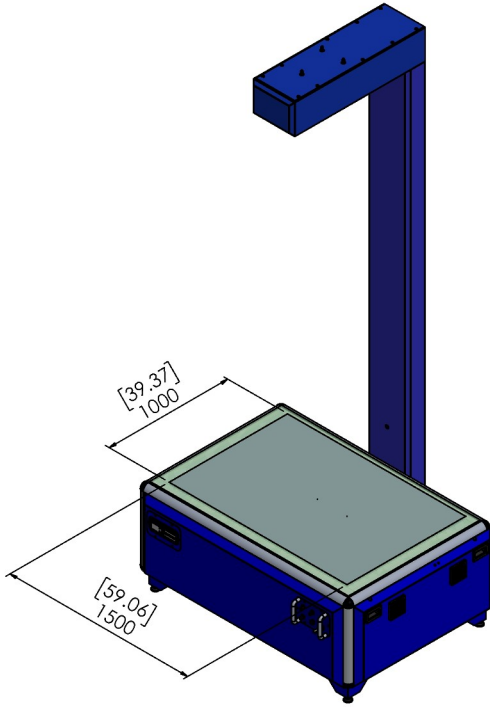

DIMENSIONS IN BRACKETS ARE IN INCHES