

Specification and scope of supply of Opti-Scan 1000.35

Description	Specification/scope of supply
Max Single scan area ^{1&2}	1000mm (X) x 625mm (Y)
Max Single scan depth* ^{1,2&3}	625mm (Z)
Volumetric accuracy**	75 microns
Repeatability**	35 microns
Point Spacing	Better than 210 microns
Scanning speed***	> 250,000 points per second.
Scanning time***	< 10 seconds
Processing time****	< 5 seconds
Peripheral equipment	USB lighting controller, Standard Computer Interface
Recommended Operating System	Windows 10 64bit
Software included:	3D scanning, automated repositioning, texture map acquisition, 3D color rendering, creation of cross-sections, creation of 3D edges, reverse engineering of 3D edges to DXF/DWG, comparison of 3D edges to DXF/DWG, reverse projection of colored deviation reports onto part, creation of 3D point clouds in PLY, STL, VRML, ASCII formats, creation of texture mapped point clouds, calibration software.
Free 3D Inspection Software:	Fully compatible with off the shelf free 3D inspection software. Functionality includes comparison to 3D solid models, dimensioning, GD&T, cross-sections, full surface deviation inspection, merging of scans, customizable reports, automatic alignment of scan to CAD, point cloud meshing, processing and filtering, extraction of nominal data from CAD model, comparison of 2 scans.
Advanced 3D inspection software option (Geomagic Control)	Available on request. Comparison to 3D solid models, GD&T, SPC, cross-sections, full surface and edge inspection, creation of report templates, automated merging of point clouds, automatic alignment of scan to CAD, automatic point cloud processing and filtering, automatic detection or repositioning spheres, macro creation for full automation, automatic extraction of nominal data from CAD model, comparison of 2 scans.
3D reverse engineering (advanced package)	Available on request. Creation of 3D solid models from scan data.
Calibration Kit	Included as standard, retro-reflective reference markers mounted onto steel plate with repositioning frame
Accuracy Verification Object	Included as standard, calibrated ball bar
OptiScan construction	Heavy duty aluminium tripod, dolly base. Camera and projector assemblies mounted on floating carbon fibre chassis
OptiScan enclosure	ABS Carbon fibre effect
Repositioning markers	Set of 24 loose magnetic photogrammetric markers to allow repositioning
Optional light table	Optional light table for improved edge measuring accuracy. Manual or automatic component repositioning disc options
Automated turn-table maximum load (UDL)	50kg
Camera	>20 megapixels
Projection source	LED/laser projector.
Data cables	HDMI and USB3
Air Supply	The air supply for the air bearing can come from a small compressor if no factory air supply is available. The compressor should have a minimum receiver capacity of 24 litres.
Air supply hose	The air supply hose should be 3/8 inch bore to be a push fit onto a brass tail pipe connection.
Air flow	Air flow – 4.5 to 5.0 CFM @ 100psi FAD (Free Air Delivery)
Air pressure	Air pressure input range – 110psi to 140psi (approx 7.5 to 8 bar).
Air quality	Air quality – clean, dry, oil-free air.
Power supply	110-240V 50/60Hz
Power consumption	1.5 Amp maximum at 230 Volt, 3 Amp max at 110 Volt.
EC directives	Compliant with Machinery, Low voltage and EMC Directives.
Paint colour (powder paint)	Tripod and Dolly RAL 9005: Black Light table RAL 5013 (cobalt blue)
Ambient operating conditions	5-35 degree C
Available configurations	LA= Light Table Automatic Repositioning disc LM = Light Table Manual Repositioning disc or tripod
Approx Footprint width/ depth/ height/ weight	1124mm (W) x 791mm (D) x 1574mm (H) <45kgs (Tripod)
Approx Footprint width/ depth/ height/ weight	3154mm (W) x 1469mm (D) x 2005mm (H) <1000kgs (LM & LA)
Standard packing	Export crate suitable for sea shipping
Warranty	One year limited warranty on hardware and software
Optional extended warranty	Two or three year extended warranty (requires software upgrade option)
Software support option	Annual support contract provides free software upgrades

1 Larger parts can be measured with multiple scans

2 Other sizes are available on request, exact dimensions may vary by slightly depending on setup.

3 Other accuracies are available on request

*Actual scanning range will be significantly larger, however measurements outside of this range may have additional noise.

**Accuracy achieved by measuring a reference object at various locations within the measuring volume, contact InspecVision for further details.

***Time taken to measure a typical component. Results may vary depending on part measured or speed of computer

****Time taken to process the measurements of a typical component. Results may vary depending on part measured or speed of computer.

Actual measuring accuracies achieved will depend on operating environment, user input, quality and condition of materials

Due to our policy of continuous improvement specifications are subject to change without notice, please contact factory or your InspecVision dealer

+52 (81) 8625 9815

info@camconnection.com

www.camconnection.com

InspecVision Showrook
Av. Rogelio González Caballero
100, Local 12, Parque Industrial
Stivia, 66600 cd. Apodaca, N.L

Opti-Scan 1000.35 LA Schematic

DIMENSIONS IN BRACKETS ARE IN INCHES
OS.1000.35
AVAILABLE MODELS:
-OS.1000 LM MANUAL OPERATION
-OS.1000 LA AUTOMATIC OPERATION

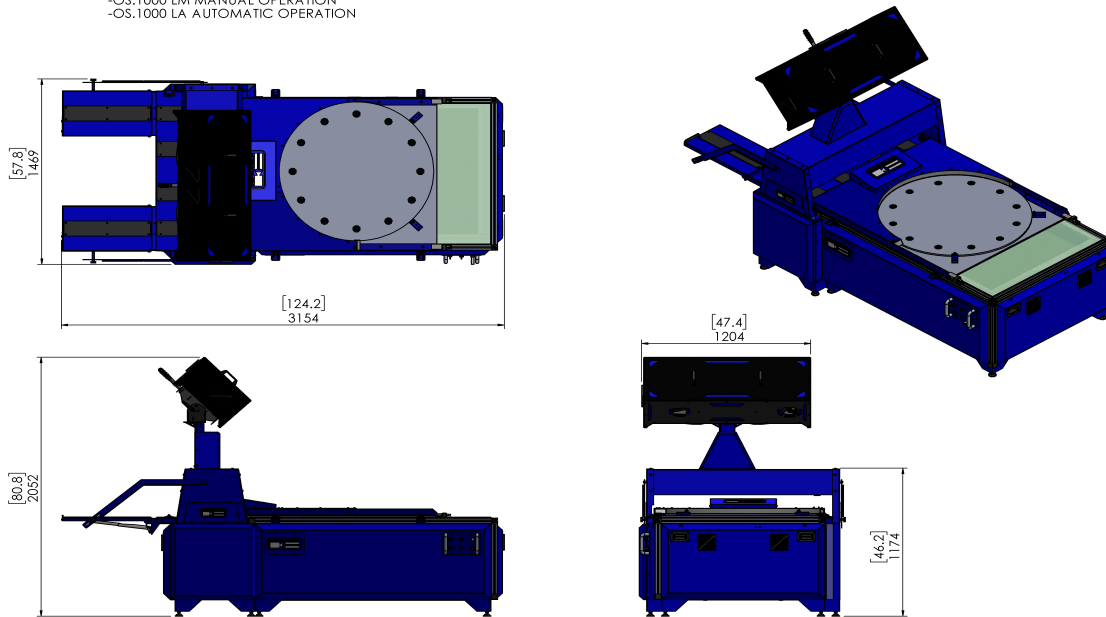

Standalone Opti-Scan 1000.35 Schematic

